



203 SERIES TGW

CARBON STEEL/AISI 316



Designed for high pressure applicaitons.
Poppet Valve closing system.
BSP, NPTF threads and other upon request.

• Materials

Carbon Steel EN -10277-3 , AISI 316 and AISI 303

Seals: NBR, Viton or EPDM

Back-up-ring: PTFE

Springs: Carbon Steel DIN 17233/84(B)

• Working temperature (Seals)

	NBR	Viton	EPDM
	+100°C	+200°C	+150°C
	-30°C	-10°C	-40°C

- **Applications:** Designed for Oil hydraulic Applications according to European Directive 97.23.EC Hammer Application

• Equivalence

GROMELLE 6000
TUTHILL 6000

• Sectors: Industrial



MODEL STRUCTURE

Example:

203.11115 AF

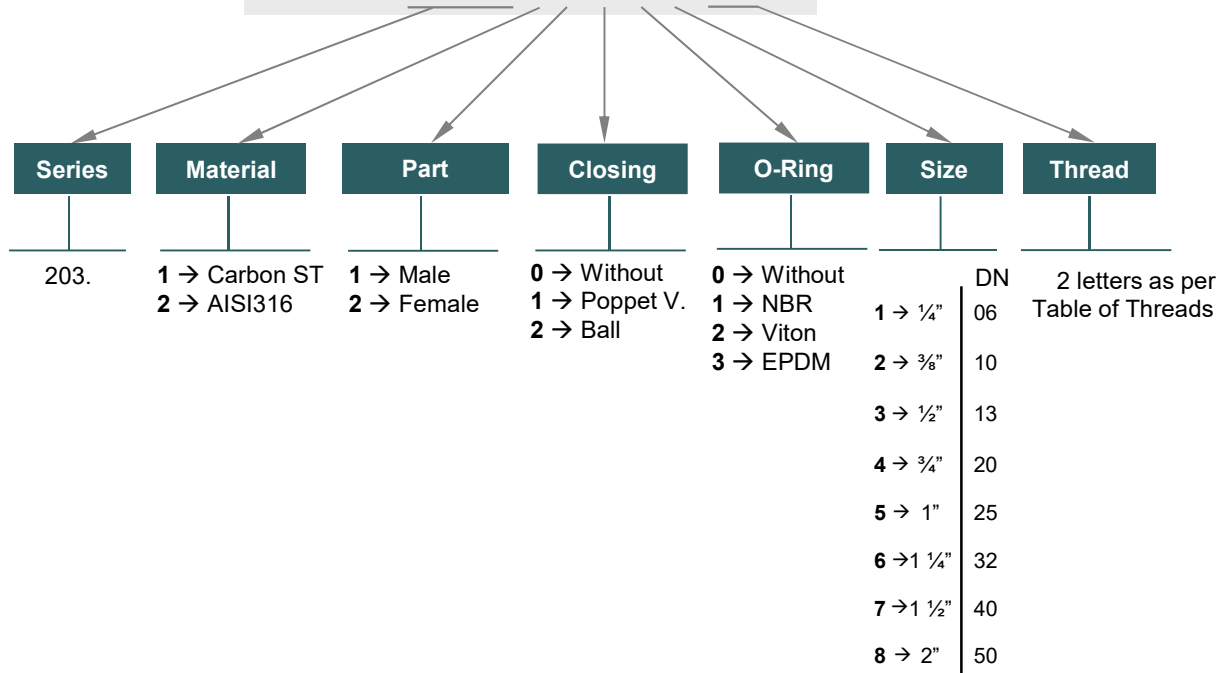

203-1



203 SERIES TGW

CARBON STEEL



MALE					
DN	CH	C	ØF	ØG	L
06	30	44	14,90	M27x1,5	88
10	32	40,50	18,95	M30x1,5	81
13	38	49	22	M35x1,5	98
20	50	56	28,95	M45x1,5	112
25	60	68	36	M54x1,5	136
32	75	75	49,80	M70x2	150
40	60	93	55	M78x2	176.5
50	70	128	69,40	M92x3	247

STANDARD MODELS				
DN	ØA	MALE	FEMALE	
06	1/4" BSP	203.11111AB	203.12111AB	950Bar
	1/4" NPTF	203.11111BB	203.12111BB	
10	3/8" BSP	203.11112AC	203.12112AC	750Bar
	3/8" NPTF	203.11112BC	203.12112BC	
13	1/2" BSP	203.11113AD	203.12113AD	750Bar
	1/2" NPTF	203.11113BD	203.12113BD	
20	3/4" BSP	203.11114AE	203.12114AE	650Bar
	3/4" NPTF	203.11114BE	203.12114BE	
25	1" BSP	203.11115AF	203.12115AF	450Bar
	1" NPTF	203.11115BF	203.12115BF	
32	1 1/4" BSP	203.11116AG	203.12116AG	450Bar
	1 1/4" NPTF	203.11116BG	203.12116BG	
40	1 1/2" BSP	203.11117AH	203.12117AH	300Bar
	1 1/2" NPTF	203.11117BH	203.12117BH	
50	2" BSP	203.11118AI	203.12118AI	300Bar
	2" NPTF	203.11118BI	203.12118BI	

FEMALE				
DN	CH2	B	CH1	L
06	19	66.75	32	88
10	22	67	36	81
13	27	76.20	41	98
20	32	89.30	50	112
25	41	107,50	65	136
32	55	130,50	80	150
40	60	143,50	85	176.5
50	70	203,50	105	247



203 SERIES TGW

CARBON STEEL



TECHNICAL DATA					
DN	Rated Flow	Min Burst Pressure (bar)			Max. Working Pressure
		Male	Female	Coupled	
06	18 l/m	3650	3500	3800	950 Bar
10	38 l/m	3000	2900	3000	750 Bar
13	62 l/m	2950	3000	3000	750 Bar
20	116 l/m	2520	2500	2600	650 Bar
25	194 l/m	1800	1650	1800	450 Bar
32	290 l/m	1700	1650	1800	450 Bar
40	450 l/m	1100	1250	1200	300 Bar
50	630 l/m	1100	1100	1200	300 Bar

Test performed according to ISO 18869

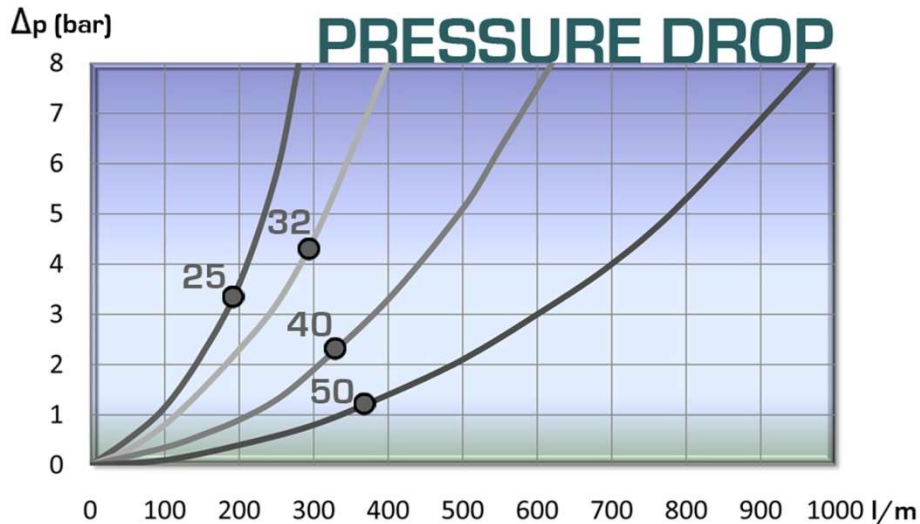
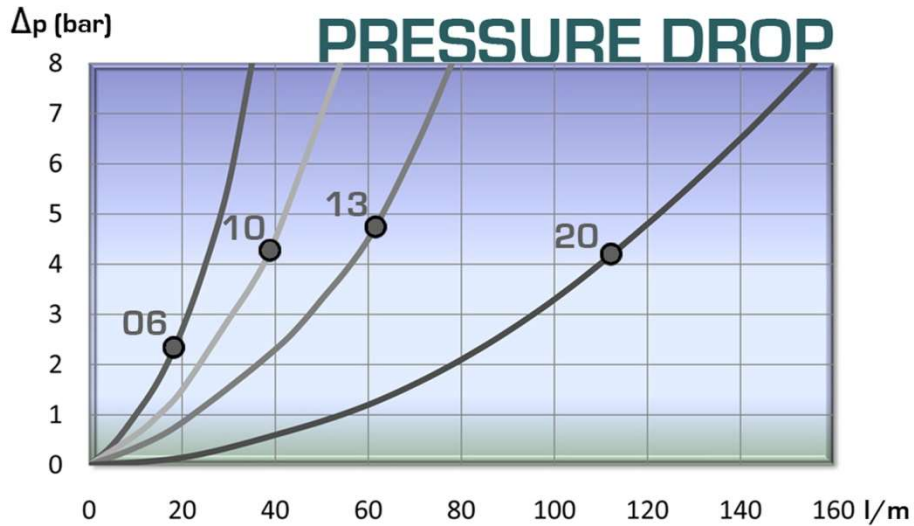

203-3





203 SERIES TGW

AINI 316



MALE					
DN	CH	C	ØF	ØG	L
06	30	44	14,90	M27x1,5	88
10	32	40,50	18,95	M30x1,5	81
13	38	49	22	M35x1,5	98
20	50	56	28,95	M45x1,5	112
25	60	68	36	M54x1,5	136
32	75	75	49,80	M70x2	150
40	60	93	55	M78x2	176.5
50	70	128	69,40	M92x3	247

STANDARD MODELS				
DN	ØA	MALE	FEMALE	
06	1/4" BSP	203.21111AB	203.22111AB	950Bar
	1/4" NPTF	203.21111BB	203.22111BB	
10	3/8" BSP	203.21112AC	203.22112AC	750Bar
	3/8" NPTF	203.21112BC	203.22112BC	
13	1/2" BSP	203.21113AD	203.22113AD	750Bar
	1/2" NPTF	203.21113BD	203.22113BD	
20	3/4" BSP	203.21114AE	203.22114AE	650Bar
	3/4" NPTF	203.21114BE	203.22114BE	
25	1" BSP	203.21115AF	203.22115AF	450Bar
	1" NPTF	203.21115BF	203.22115BF	
32	1 1/4" BSP	203.21116AG	203.22116AG	450Bar
	1 1/4" NPTF	203.21116BG	203.22116BG	
40	1 1/2" BSP	203.21117AH	203.22117AH	300Bar
	1 1/2" NPTF	203.21117BH	203.22117BH	
50	2" BSP	203.21118AI	203.22118AI	300Bar
	2" NPTF	203.21118BI	203.22118BI	

FEMALE				
DN	CH2	B	CH1	L
06	19	66.75	32	88
10	22	67	36	81
13	27	76.20	41	98
20	32	89.30	50	112
25	41	107,50	65	136
32	55	130,50	80	150
40	60	143,50	85	176.5
50	70	203,50	105	247



203 SERIES TGW

AISI 316



TECHNICAL DATA					
DN	Rated Flow	Min Burst Pressure (bar)			Max. Working Pressure
		Male	Female	Coupled	
06	18 l/m	3650	3500	3800	950 Bar
10	38 l/m	3000	2900	3000	750 Bar
13	62 l/m	2950	3000	3000	750 Bar
20	116 l/m	2520	2500	2600	650 Bar
25	194 l/m	1800	1650	1800	450 Bar
32	290 l/m	1700	1650	1800	450 Bar
40	450 l/m	1100	1250	1200	300 Bar
50	630 l/m	1100	1100	1200	300 Bar

Test performed according to ISO 18869

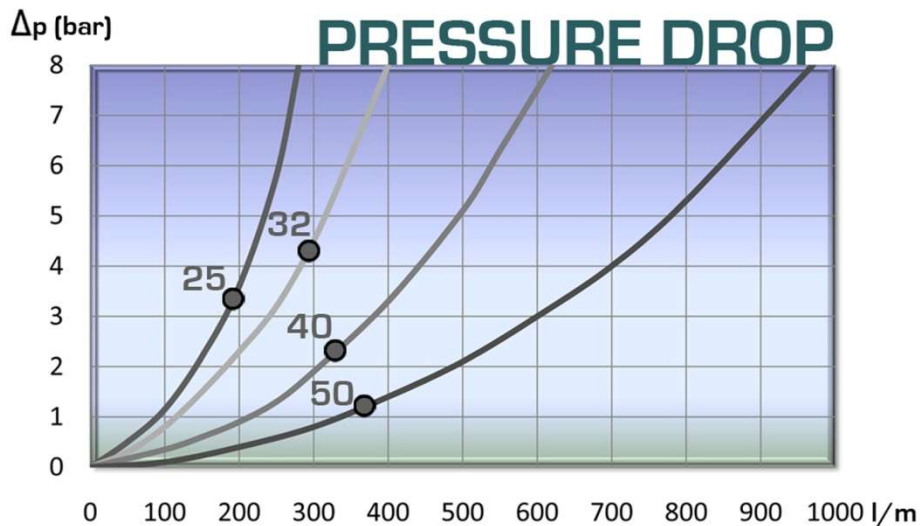
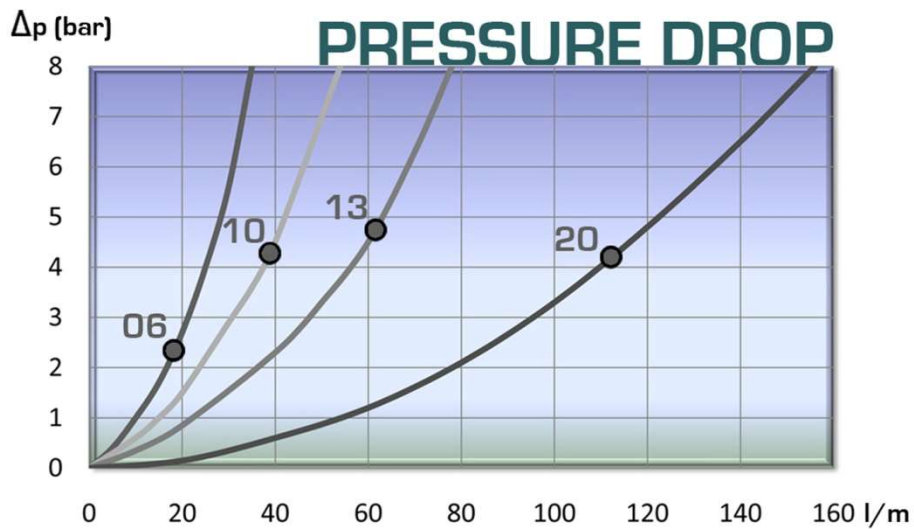

203-5





203 SERIES

TGW PLUGS & CAPS



TGW SERIES PLUGS, CAPS and have been designed to protect FEMALE (coupler) or MALE (nipple) parts while they are disconnected.

MODEL STRUCTURE

Example:

203.6404 AA

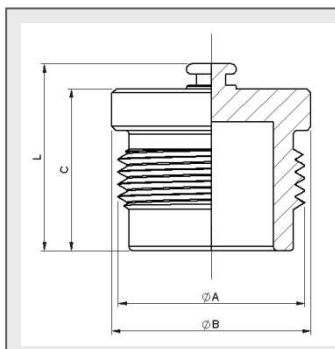
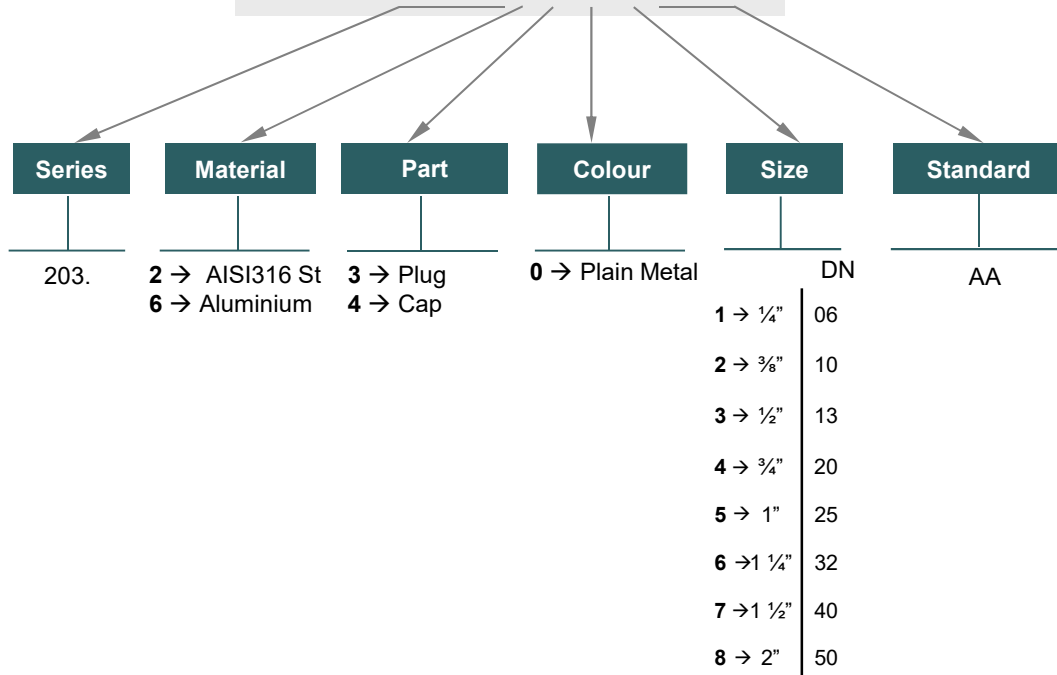

PLUG				
DN	REF.	ØA	ØB	L
06	203.6301AA	M27x1.5	32	24.5
10	203.6302AA	M30x1.5	35	26.5
13	203.6303AA	M35x1.5	40	26.5
20	203.6304AA	M45x1.5	50	32
25	203.6305AA	M54x1.5	60	38
32	203.6306AA	M70x2	75	45
40	203.6307AA	M78x2	84.5	47
50	203.6308AA	M92x3	117	61

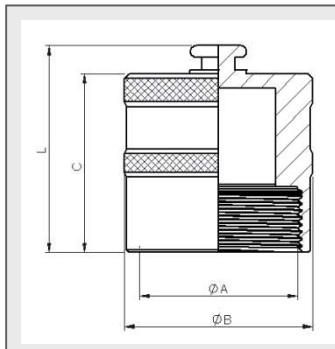

CAP				
DN	REF.	ØA	ØB	L
06	203.6401AA	M27x1.5	32	40
10	203.6402AA	M30x1.5	35	43
13	203.6403AA	M35x1.5	40	41
20	203.6404AA	M45x1.5	50	52
25	203.6405AA	M54x1.5	60	61
32	203.6406AA	M70x2	75	80
40	203.6407AA	M78x2	85	83
50	203.6408AA	M92x3	102	116

203-6