

Transfer Gear Pumps

Construction of the Gear Pump KF

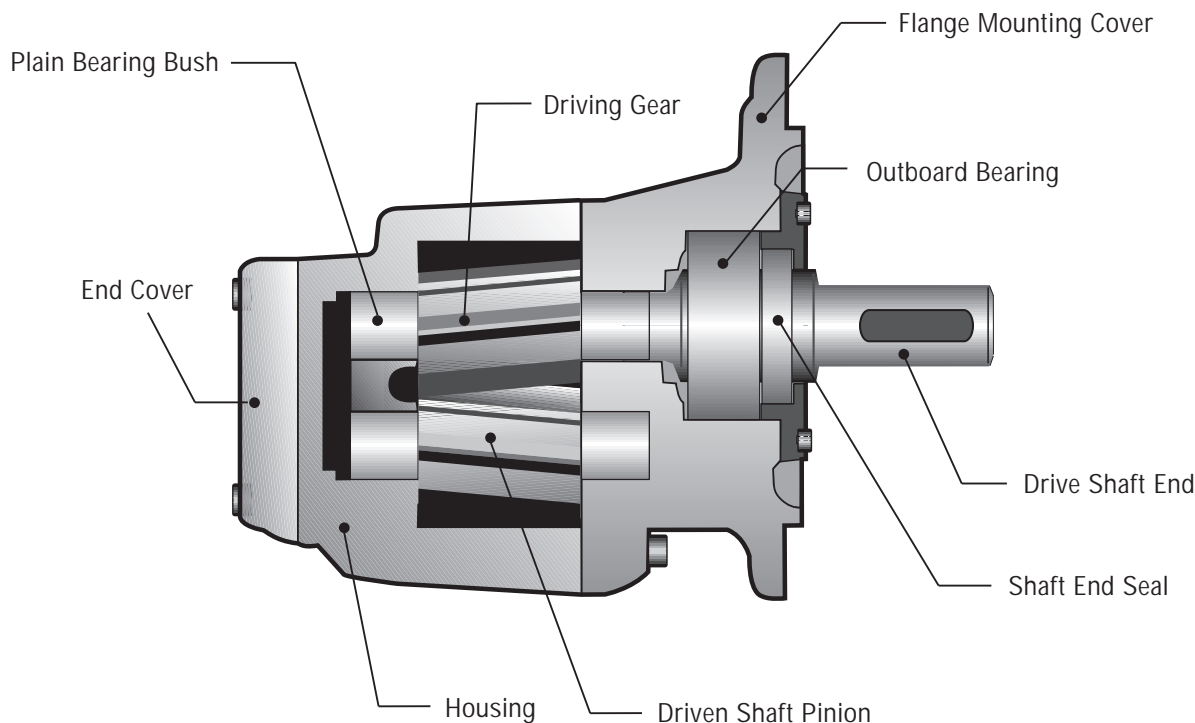

Product Features

KF gear pumps are used for pumping a wide variety of fluids. KF gear pumps are distinguished especially by their wide range of variants which are assembled as required on the modular principle and also permit subsequent upgrade.

The pumps are also suitable for media with low lubricating properties.

The standard housing sections are of grey cast iron.

The gear units are manufactured from high-strength case-hardening steel, hardened and mounted in special multi-compound plain bearing bushes.

The standard drive shaft is sealed by rotary shaft lip-type seal.

All pump sizes incorporate helical tooth system.

This feature, combined with special gear geometry, results in extremely low noise levels and reduced pressure pulsation.

Variants:

- Sealing of the drive shaft
 - Rotary shaft lip-type seal
 - Double rotary shaft lip-type seal (Quench)
 - Mechanical seal
- Outboard bearing to take up input drive-side radial load
- Pressure relief valve as safety valve for pump and system
- Uniform discharge flow direction with changing direction of rotation by means of flange-mounting valve combination (universal device).

Special Constructions

To meet your individual requirements on request special constructions are available: for instance mounting flange models, various types of plane bearings, etc. Our Sales engineers will be glad to help you to equipment most appropriate for your specific purpose.

Technical Data

Size	Nominal displacement	Geometrical displacement	Operating pressure	Maximum pressure	Speed range		Perm. forces (n = 1450 1/min)		Moment of inertia*
		V _g cm ³	p _b bar	p _{max} bar	n _{min} 1/min	n _{max} 1/min	F _{radial} N	F _{axial} N	J kgm ²
3 /	100	100.8	25	30	200	2000	1500	200	6.75
	112	112.8	25	25	200	2000	1500	200	7.5
4 /	125	129	25	40	200	2000	1500	200	13.75
	150	153	25	30	200	2000	1500	200	16
	180	184	25	25	200	2000	1500	200	19.25
5 /	200	204	25	30	200	2000	2000	300	27.5
	250	255	20	25	200	2000	2000	300	34.5
	315	321	16	20	200	2000	2000	300	43
6 /	400	405	25	30	200	2000	3000	500	105
	500	505	20	25	200	2000	3000	500	130
	630	629	16	20	200	2000	3000	500	160

* (without coupling) x 10⁻⁴

Remark

Operating Pressure p_b = Permissible Continuous Pressure

Maximum Pressure p_{max} = nur only applicable to the operation with Mineral Oils at Speed n > 700 1/min and Viscosities v = 30 mm²/s up to 1000 mm²/s.

Permissible Forces only applicable to the Types fitted with Outboard Bearing.

F_{radial} to the middle of the Shaft End.

Characteristic Data at speed n = 1450 1/min

Operating Pressure p _b in bar													Nom. Displ. Size	Operating Pressure p _b in bar																						
2	4	6	8	10	12	14	16	18	20	22	25	2		4	6	8	10	12	14	16	18	20	22	25												
142	141	140	139	138	137	136	135	134	133	132	130	3/	100	1.2	1.7	2.2	2.7	3.2	3.7	4.2	4.7	5.2	5.7	6.2	6.9											
157	156	155	154	153	152	151	150	149	148	147	145		112	1.4	2.0	2.6	3.1	3.7	4.3	4.7	5.3	5.8	6.4	7.0	7.8											
180	178	176	175	173	171	169	168	166	164	162	160	4/	125	1.6	2.2	2.8	3.4	4.0	4.6	5.2	5.8	6.4	7.0	7.6	8.5											
215	213	212	210	208	206	205	203	201	199	197	195		150	1.9	2.6	3.3	4.0	4.8	5.5	6.2	7.0	7.7	8.4	9.2	10.6											
262	260	258	257	255	254	253	251	250	248	247	245	5/	180	2.2	3.0	3.9	4.8	5.7	6.6	7.5	8.4	9.3	10.2	11.0	12.4											
285	283	281	279	278	276	274	273	271	269	267	265		200	2.4	3.4	4.4	5.4	6.5	7.5	8.6	9.6	10.7	11.7	12.7	14.2											
356	354	351	349	347	344	342	340	338	335	6/	250	3.0	4.3	5.5	6.8	8.1	9.4	10.7	12.0	13.3	14.6	500	7.3	9.8	12.3	14.7	17.2	19.6	22.0	24.5	27.0	29.4				
450	448	447	446	444	443	442	441	315	3.7		5.3	6.9	8.6	10.2	11.7	13.4	15.0	630	9.3	12.0	15.0		18.0	21.0	24.0	27.0	30.0									
575	572	569	566	563	560	557	554	551	548	545	540	6/	400	5.8	7.7	9.6	11.6	13.5	15.5	17.5	19.5	21.4	23.3	25.3	28.3	500	7.3	9.8	12.3	14.7	17.2	19.6	22.0	24.5	27.0	29.4
715	711	707	703	699	695	691	688	685	681	630	9.3		12.0	15.0	18.0	21.0	24.0	27.0	30.0																	
895	891	887	883	878	874	870	865																													

Discharge Flow Q in l/min

Power Input Required P in kW

The Dispersion of Discharge Flow Q as specified in the above Table may be: Q + 2,5% up to - 5%.

At Viscosities of v < 30 mm²/s Reduction of the Discharge Flow Q.

At Viscosities of v > 300 mm²/s, the Speed must be reduced.

The Drive Motor Output must be selected 20% higher than the Data for P as specified in the above Table.

For Viscosities of v > 100 mm²/s the Power Input must be increased.

Type Key

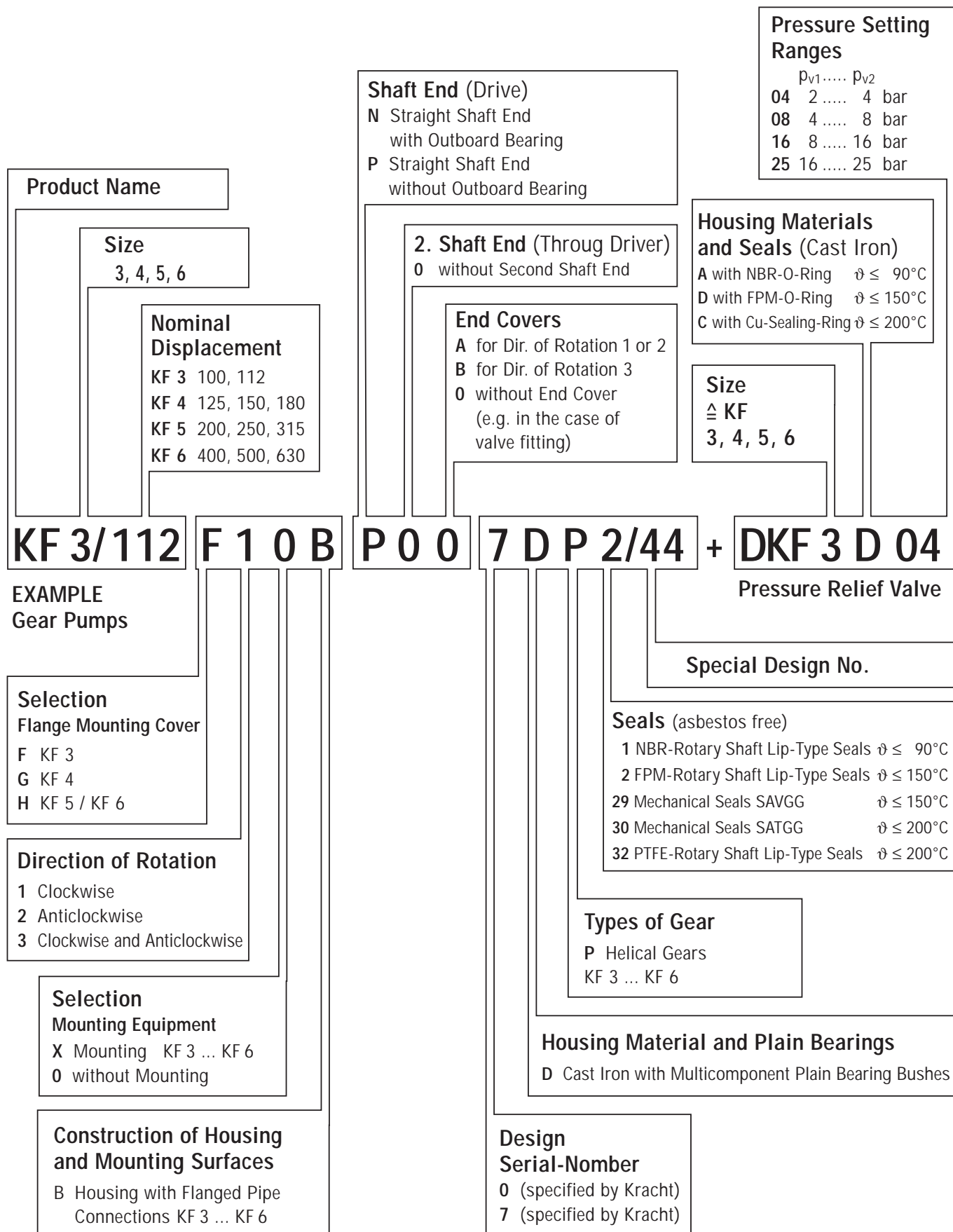

Characteristics

Allgemeine Kenngrößen

Mounting	Flange- and Angle Foot-Type
Pipe Connection	Flanged Pipe Connections, 4-Bolt-Type (Straight Flange Couplings, Welding Connectors, in addition Intermediate Flange-Heatable). Threaded Ports
Direction of Rotation	Clockwise or Anticlockwise Clockwise and Anticlockwise
Weight	Refer to Dimensional Sheets
Fitting Position	Optional (for exeptions refer to Universal Arrangement)
Permissible Ambient Temperature Range	$\vartheta_{u \min}$ = - 20 °C $\vartheta_{u \max}$ = + 60 °C

Operating Characteristics

Operating Pressures	
Suction Side $p_{e \min}$ (Inlet Port)	= - 0.4 bar (Vacuum), for short time duty e.g. when starting: down to - 0.6 bars are permissible. Observe the limitation of $p_{e \min}$ for pumps with "Universal Arrangementi"
$p_{e \max}$	= 0.5 bar for PTFE-Rotary Shaft Lip-Type Seals = 1.0 bar for NBR- and FPM Rotary Shaft Lip-Type Seals = 10 bars for Mechanical Seals
Pres. Side p_n (Outlet Port)	= 25 bars
Fluid Temperature Range	$\vartheta_{m \min}$ = - 10 °C $\vartheta_{m \max}$ = 90 °C for NBR-Rotary Shaft Lip-Type Seals = 150 °C for FPM Rotary Shaft Lip-Type Seals and Mechanical Seals SAVGG = 200 °C for PTFE Rotary Shaft Lip-Type Seals = 200 °C for Mechanical Seals SATGG or Ord. Code refer to Page 4 + 5
Viscosity Range	v_{\min} = 12 mm ² /s v_{\max} = 15000 mm ² /s Viscosities other than within this range on request
Discharge Flow	Refer to Table Page 3
Power Input	Refer to Table Page 3
Speeds	n_{\min} = 200 1/min n_{\max} = 2000 1/mn The permissible max. speed depends upon the viscosity of the medium operated acc. to the table on the right site

Suitable Fluids

Waste oils	Resins	Paraffins
Soluble oils	Hardening oils	Polyols
Diesel oils	Fuel oils, L, EL, H	Lubricating oils
Printing inks	Hydraulic fluids	Cutting oils
Emulsions	Isocyanate	Heavy oils
Dyes	Adhesives	Heat transfer media
Fats	Plastics	Processing oils
Antifreeze	Engine oilse	Waxes
Gear oils	Nitrocellulose lacquers	Rolling oils
		Drawing compounds

Accessories

Flanged Pipe Connections 4-Bolt-Type	Foot Mounting Flanges for the Adaptor Flanges below
Mounting Angles	Base Plates
Pressure Relief Valves (attachable subsequently)	Couplings
	Adaptor Flanges (Pump Carrier)

Other Types

ZM; ZN Pump with Electric Motor directly connected to each other by an Adaptor Flange.

Kinematic Viscosity v mm²/s

<	300	300	500	1000	2000	3000	6000	10000	20000	30000
≥	1500	1250	1000	750	600	500	400	300	200	100

max. Speed n_{\max} 1/min

Note:

The above specified Minimum and Maximum Characteristics are NOT applicable for some specific operating conditions: Maximum Operating Pressure is NOT permissible in conjunction with low speeds and low viscosities. Please contact us whenever such critical ranges are encountered.

Operating Notes

Operating Notes:

- The fluids should ensure a certain minimum lubricating properties, should not contain solids and should be chemically compatible.
- Avoid dry operation.
- The pumps may only be operated in the specified direction of rotation, as otherwise the shaft seal will be destroyed.
- In order to prevent excessive overpressure, a safety valve should be provided in the system or on the pump.
- The pressure relief valve attached to the pump may only be used as safety valve for short-term operation.
- To drain off a partial discharge flow over a prolonged period, a separate pressure relief valve with return line must be inserted in the reservoir.

Direction of Rotation:

The following should be noted for direction of rotation:

- when looking at the pump shaft end, the direction of pumping is from left to right if the shaft rotates **clockwise**.
- when looking at the pump shaft end, the direction of pumping is from right to left if the shaft rotates **counterclockwise**.

With Pressure Relief Valve

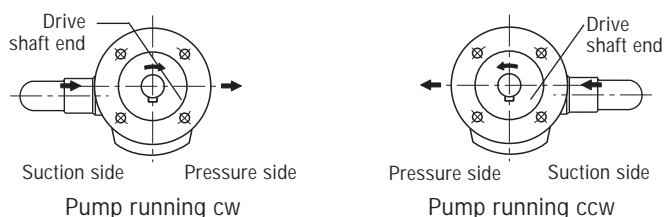

With our decades of experience, we are at your side, world-wide, for the professional mastery of specific applications and complete solutions in hydraulics and process technology.

Gear Pumps KF

Flange-Type Pumps of Grey Cast Iron

Materials

Housing components: Cast iron with lamellar graphite acc. to DIN 1691

Shafts and gears: Case hardening steel acc. to DIN 17210 surface hardened and grinded

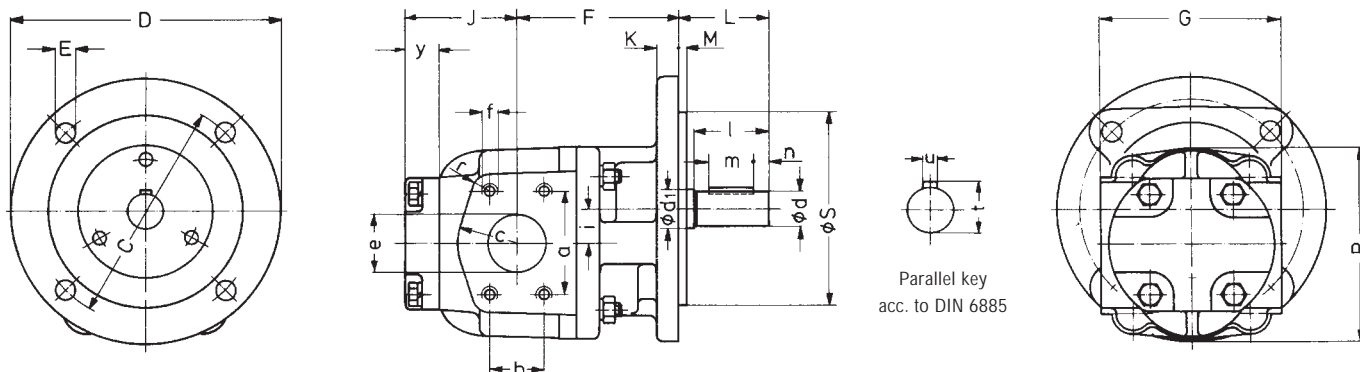

Size	Inlet- and outlet port pipe thread											Shaft end											Weight kg										
	a	b	c	e	f	k	p	r	C	D	E	F	G	J	K	L ₁	M	N	N ₁	R	S _{h6}	i		Y	d ₁	d _{k6}	l	m	n	t	u		
3/100 112	69.9	35.7	40	40	M10	16 deep	2	13	12	150	180	14	108	120	92	15	120	5	69	65	130	130	23	20	25	24	50	30	10	27	8	13.5	
															92										20	19	50	30	5	21.5	6		
4/150 180	77.8	42.9	50	50	M12	18 deep	2	13	12	185	220	18	125	130	80	19	125	8	69	69	160	150	28.3	20	25	24	50	40	5	27	8	18.5	
															77																	20	21
5/250 315	88.9	50.8	55	63					13				155		93										30	28	60	40	10	31	8	28	
	106.4	61.9	65	75	M12	20 deep	2	13	15	215	250	18	170	150	109	22	125	8	61	61	198	180	32	24								33	
	106.4	61.9	65	75					15				170		109																	33	
6/400 500 630	130.2	77.8	80	100	M16	32 deep	2	12	20				180		124										40	38	80	63	8	41	10	51	
										215	250	18	200	200	126	25	160	8	72	69	244	180	40	24								55	
													200		159																	65	

Gear Pumps KF

Flange-Type Pumps of Grey Cast Iron with Pressure Relief Valve

Materials

Housing components: Cast iron with lamellar graphite acc. to DIN 1691

Shafts and gears: Case hardening steel acc. to DIN 17210 surface hardened and grinded

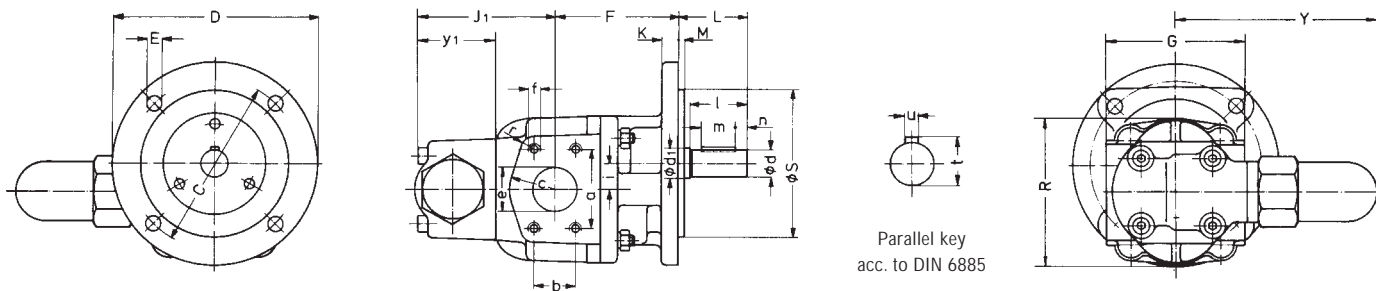

Parallel key
acc. to DIN 6885

Size	Inlet- and outlet port pipe thread												Shaft end										Weight kg								
	a	b	c	e	f	k	p	r	C	D	E	F	G	J	K	L ₁	M	R	Sh ₆	Y	i	y ₁		d ₁	dk ₆	l	m	n	t	u	
3/100 112	69.9	35.7	40	40	M10	16 deep	2	13	12	150	180	14	108	120	92	15	120	5	130	130	160	23	60	25	24	50	30	10	27	8	15
	20	19	50	30	5	21.5	6							92																	
4/125 150 180	77.8	42.9	50	50	M12	18 deep	2	13	12	185	220	18	125	130	110	19	125	8	160	150	171	28.3	70	25	24	50	40	5	27	8	20 21.5 22.5
													135		80																
5/200 250 315	88.9	50.8	55	63					13				155		93									30	28	60	40	10	31	8	30 35 35
	106.4	61.9	65	75	M12	20 deep	2	13	15	215	250	18	170	150	109	22	125	8	198	180	196	32	77								
6/400 500 630	130.2	77.8	80	100	M16	32 deep	2	12	20				180		124									40	38	80	63	8	41	10	59 63 73
										215	250	18	200	200	126	25	160	8	244	180	238	40	110								

Addition to type key on page 4

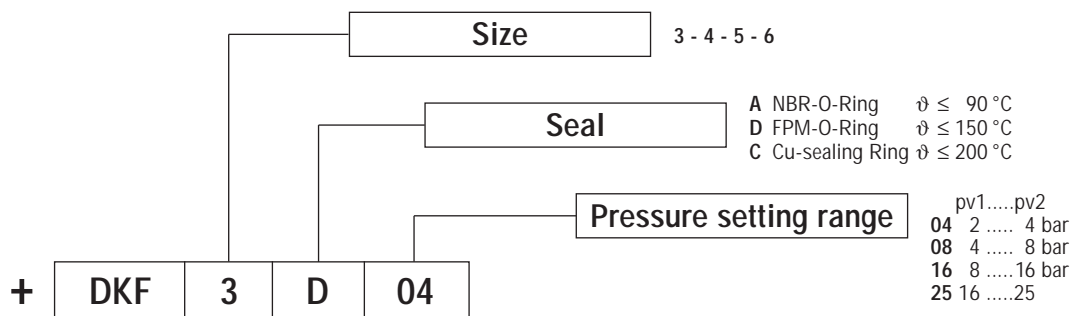

Gear Pumps KF

Flange-Type Pumps of Grey Cast Iron with Mechanical Seal

Materials

Housing components: Cast iron with lamellar graphite acc. to DIN 1691

Shafts and gears: Case hardening steel acc. to DIN 17210 surface hardened and grinded

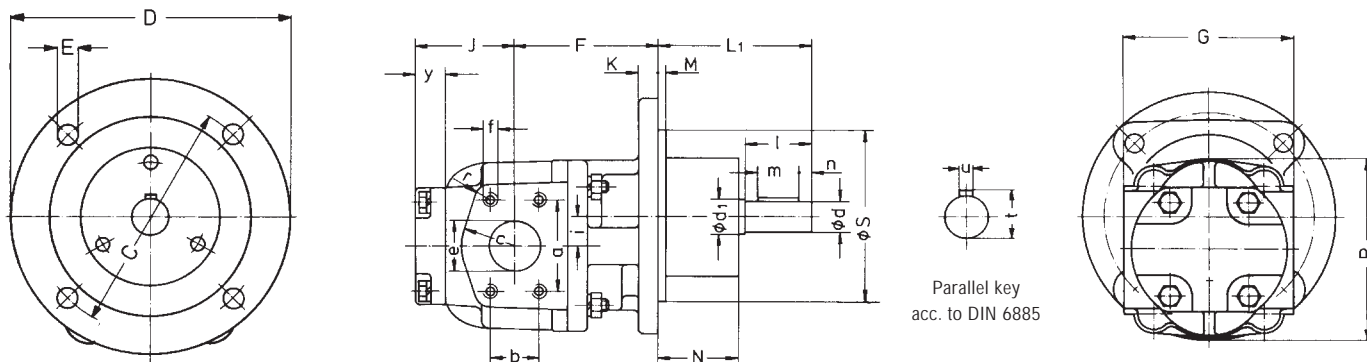

Size	Inlet- and outlet port pipe thread							Shaft end													Weight kg								
	a	b	c	e	f	r	C	D	E	F	G	J ₁	K	L ₁	M	N	R	S _{h6}	i	Y		d ₁	d _{k6}	l	m	n	t	u	
3/100 112	69.9	35.7	40	40	M10	16 deep	12	150	180	14	108	120	92	15	120	5	69	130	130	23	20	25	24	50	30	10	27	8	15
4/125 150 180	77.8	42.9	50	50	M12	18 deep	12	185	220	18	125	130	77	19	125	8	69	160	150	28.3	20	25	24	50	40	5	27	8	20 21.5 22.5
5/200 250 315	88.9	50.8	55	63			13				155		93									30	28	60	40	10	31	8	30 35 35
6/400 500 630	130.2	77.8	80	100	M16	32 deep	20	215	250	18	200	200	126	25	160	8	72	244	180	40	24	40	38	80	63	8	41	10	54 58 68

Gear Pumps KF

Flange-Type Pumps of Grey Cast Iron with Mechanical Seal and Pressure Relief Valve

Materials

Housing components: Cast iron with lamellar graphite acc. to DIN 1691

Shafts and gears: Case hardening steel acc. to DIN 17210 surface hardened and grinded

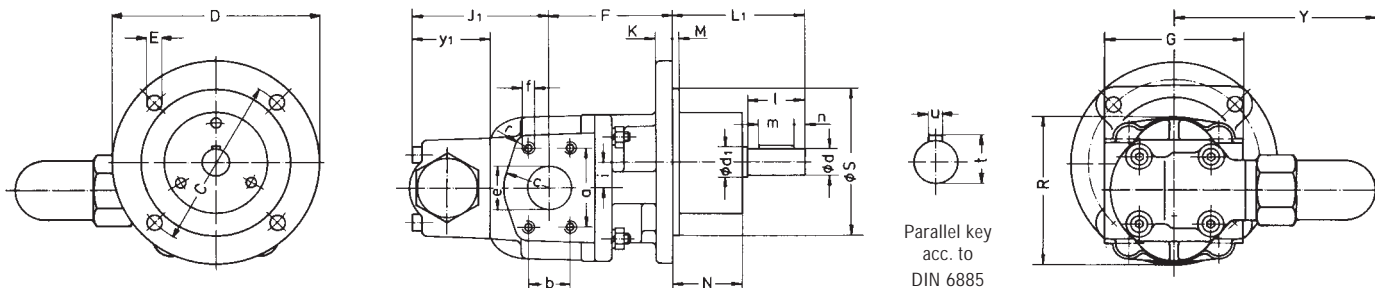

Size	Inlet- and outlet ports pipe thread												Shaft end										Weight kg														
	a	b	c	e	f	r	C	D	E	F	G	J ₁	K	L ₁	M	N	R	Sh ₆	i	Y	y ₁	d ₁		d _{k6}	l	m	n	t	u								
3/100 112	69.9	35.7	40	40	M10	16 deep	12	150	180	14	108	120	132	15	120	5	69	130	130	23	20	60	25	24	50	30	10	27	8	20	19	50	30	5	21.5	6	16.5
4/125 150 180	77.8	42.9	50	50	M12	18 deep	12	185	220	18	125	130	127	19	125	8	69	160	150	28.3	20	70	25	24	50	40	5	27	8							21.5 23 24	
5/200 250 315	88.9	50.8	55	63			13						155		146																						32 35 35
6/400 500 630	130.2	77.8	80	100	M16	32 deep	20	215	250	18	200	200	212	25	160	8	72	244	180	40	24	110	40	38	80	63	8	41	10							62 66 76	

Addition to type key on page 4

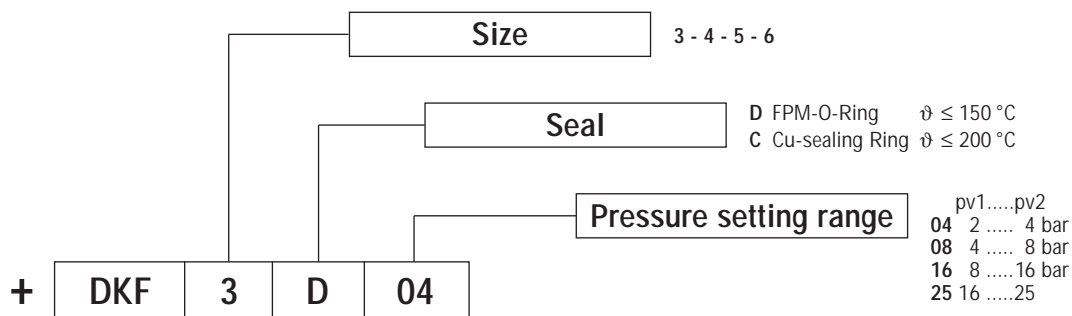

Gear Pumps KF

Flange-Type Pumps, Type Z (incl. AI Adaptor and Coupling)

Beginning with the electric motor frame size 225 the adaptor flanges are provided with 8 tapholes and additionally with 8 through holes.

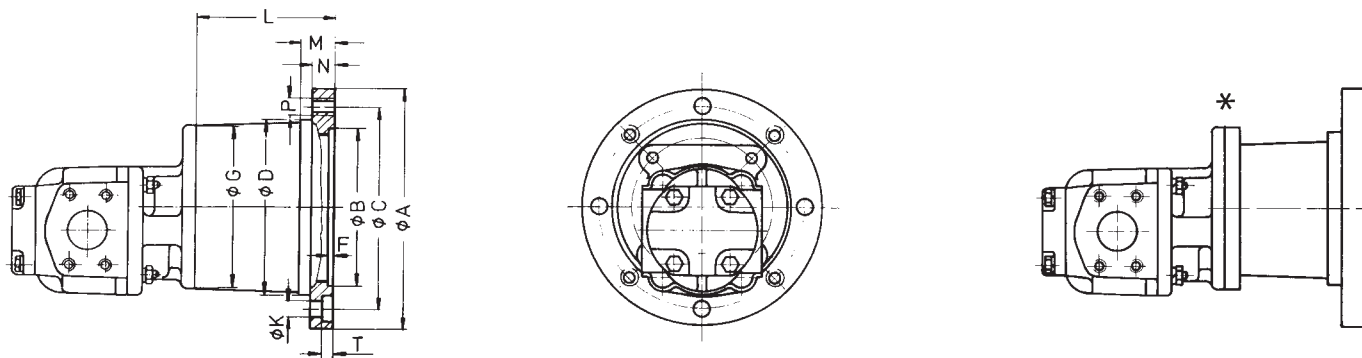

The length dimensions as specified are not applicable for types with mechanical seals.

Those adaptor flanges marked by * are not suitable for installations into reservoirs the pump flange dia. is larger than than the centering dia. of the adaptor flange.

Ordering Example:

KF 3/100 F 1 OB POA 7DP2 – Type Z 3/250/135

Size	Version designation	Drawing-No.	Frame size e-motor														adaptor flange weight kg	Coupling size
				A	B	C	D	F	G	K	L	M	N	P	T			
3/ ...	Z 3/250/135	4118229/4	100/112	250	180	215	190	5	180	14	135	33	18	M12	13	2.0	RA 28 - Z 35/19 - Z 35/28	
	Z 3/300/180	4110010/4	132	300	230	265	234	5	230	14	180	35	20	M12	13	3.8	RA 38 - Z 45/19 - Z 45/38	
	Z 3/350/204	4118230/4	160	350	250	300	260	6	230	17	204	40	25	M16	17	3.6	RA 38/45 - Z 45/19 - Z 45/42	
	Z 3/350/204	4118230/4	180	350	250	300	260	6	230	17	204	40	25	M16	17	3.6	RA 42/55 - Z 50/19 - Z 50/48	
4/ ...	Z 4/250/138*	4110012/4	100/112	250	180	215	190	5	215	14	138	33	23	M12	16.5	4.0	RA 24/28 - Z 30/24 - Z 30/28	
	Z 4/300/168	4119206/4	132	300	230	265	234	5	230	13	160	35	20	M12	13	2.7	RA 28/38 - Z 35/24 - Z 35/38	
	Z 4/350/204	4118231/4	160	350	250	300	260	6	230	17	204	40	25	M16	17	3.6	RA 38/45 - Z 45/24 - Z 45/42	
	Z 4/350/204	4118231/4	180	350	250	300	260	6	230	17	204	40	25	M16	17	3.6	RA 42/55 - Z 50/24 - Z 50/48	
5/ ...	Z 5/300/195*	4110015/4	132	300	230	265	234	5	260	14	195	35	20	M12	13	4.6	RA 38/45 - Z 45/28 - Z 45/38	
	Z 5/350/204	4118232/4	160	350	250	300	260	6	252	17	204	40	25	M16	17	4.0	RA 38/45 - Z 45/28 - Z 45/42	
	Z 5/350/204	4118232/4	180	350	250	300	260	6	252	17	204	40	25	M16	17	4.0	RA 42/55 - Z 50/28 - Z 50/48	
6/ ...	Z 6/350/237	4118233/4	160	350	250	300	260	6	252	17	237	40	25	M16	17	5.2	RA 38/45 - Z 45/38 - Z 45/42	
	Z 6/350/237	4118233/4	180	350	250	300	260	6	252	17	237	40	25	M16	17	5.2	RA 42/55 - Z 50/38 - Z 50/48	
	Z 6/400/228	4110018/4	200	400	300	350	300	6	260	17	228	40	25	M16	17	6.2	RA 42/55 - Z 50/38 - Z 50/55	
	Z 6/450/262	4110190/4	225	450	350	400	350	6	260	17	262	40	25	M16	17	8.5	RA 48/60 - Z 56/38 - Z 56/60	
	Z 6/550/275	4118234/4	250	550	450	500	450	6	260	17	275	41	26	M16	17	13.4	RA 55/70 - Z 65/38 - Z 65/65	

Adaptor flange material: Aluminium

Ordering example: KF 3/100 F 1 OB POA 7DP2 – Type Z 3/250/135 with 3-phase motor 230/400 V; 50 Hz; IP 55; 1450 min⁻¹

When ordering a flange-type pump with electric motor please specify the rated voltage, the frequency, the speed and the enclose requested.

Gear Pumps KF

Flange-Type Pumps, Type ZN and ZM

Type ZN

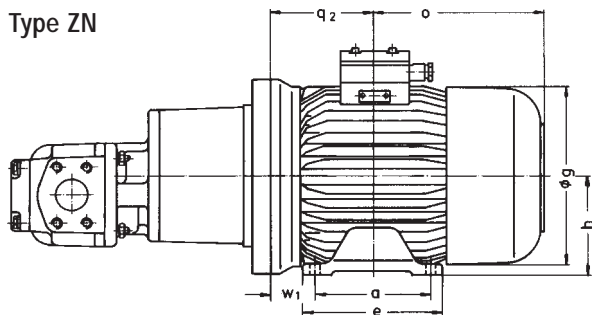

Mounting arrangement: IM B35 (V1/V5; V3/V6)

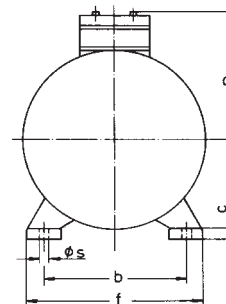

Type ZM

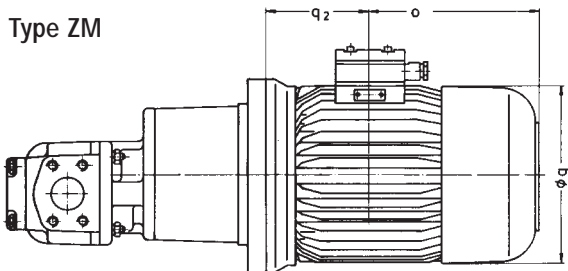

Mounting arrangement: IM B5 (V1/V3)

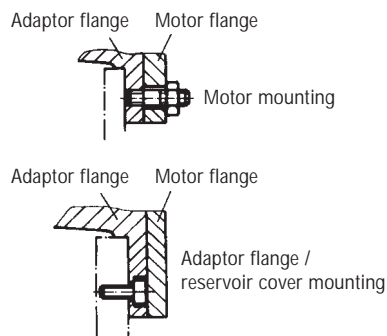

Ordering Example:

KF 3/100 F 1 OB POA 7DP2 – Type ZM 3/250/135

Type designation	Frame size	n = 1450 min ⁻¹ kW													Adaptor flange weight kg		
			a	b	c	d	f	g	h	o	q ₂	R	s	w ₁			
ZM 3/250/135	100 LS	2.2															38
ZN 3/250/135	100 L	3.0	140	160	12	167	188	198	100	221.5	101.5	140	12	63			42
ZM 4/250/138	100 LS	2.2															48
ZN 4/250/138	100 L	3.0	140	160	12	167	188	198	100	221.5	101.5	140	12	63			52

The values specified in the table above relate to ABB motors only. (Motors from other manufactures are available on request)

Ordering example: KF 3/100 F 1 OB POA 7DP2 – Type Z 3/250/135 with 3-phase motor 230/400 V; 50 Hz; IP 55; 1450 min⁻¹
 When ordering a flange-type pump with electric motor please specify the rated voltage, the frequency, the speed and the enclose requested.

Gear Pumps KF

Flange-Type Pumps, Type ZN and ZM

Type ZN

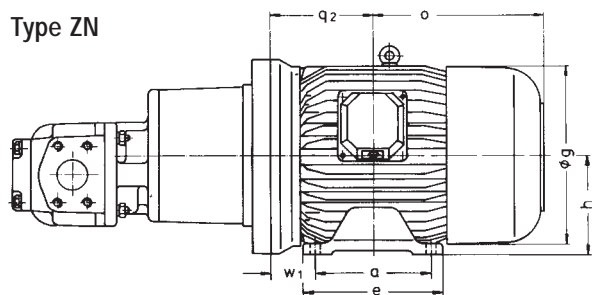

Mounting arrangement: IM B35 (V1/V5; V3/V6)

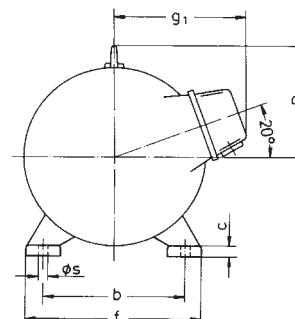

Type ZM

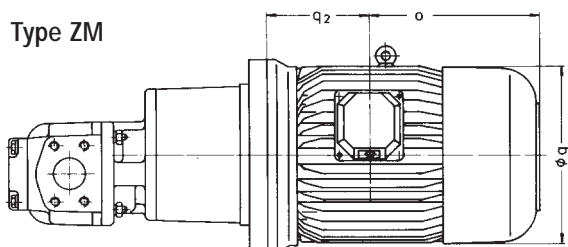

Mounting arrangement: IM B5 (V1/V3)

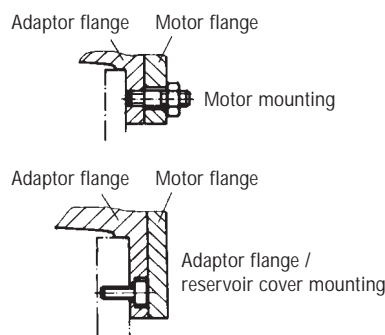

Ordering Example:

KF 3/100 F 1 OB POA 7DP2 – Type ZM 3/250/135

Type designation	Frame size	n = 1450 min ⁻¹ kW														Adaptor flange weight kg
			a	b	c	d	f	g	g ₁	h	o	q ₂	R	s	w ₁	
ZM 3/250/135 ZN 3/250/135	112 M	4	140	190	15	195	225	240	202	112	260.5	105.5	155	12	70	62
ZM 4/250/138 ZN 4/250/138	112 M	4	140	190	15	195	225	240	202	112	260.5	105.5	155	12	70	72
ZM 3/300/180 ZN 3/300/180	132 S 132 M	5.5 7.5	140 178	216	17	202 240	255	280	218	132	270 308	133	174	12	89	83 95
ZM 4/300/168 ZN 4/300/168	132 S 132 M	5.5 7.5	140 178	216	17	202 240	255	280	218	132	270 308	133	174	12	89	89 102
ZM 5/300/195 ZN 5/300/195	132 S 132 M	5.5 7.5	140 178	216	17	202 240	255	280	218	132	270 308	133	174	12	89	104 116

The values specified in the table above relate to ABB motors only. (Motors from other manufactures are available on request)

Ordering example: KF 3/100 F 1 OB POA 7DP2 – Type Z 3/250/135 with 3-phase motor 230/400 V; 50 Hz; IP 55; 1450 min⁻¹
When ordering a flange-type pump with electric motor please specify the rated voltage, the frequency, the speed and the enclose requested.

Gear Pumps KF

Flange-Type Pumps, Type ZN and ZM

Type ZN

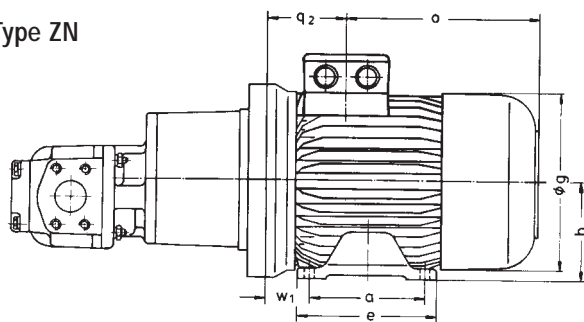

Mounting arrangement: IM B35 (V1/V5; V3/V6)

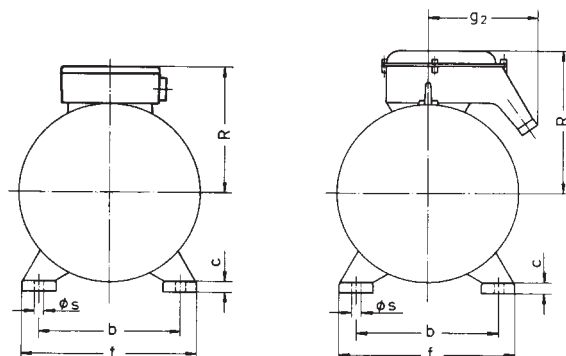

Type ZM

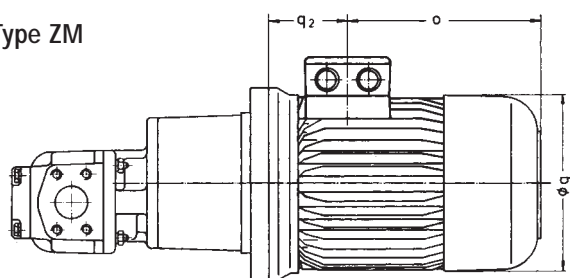

Mounting arrangement: IM B5 (V1/V3)

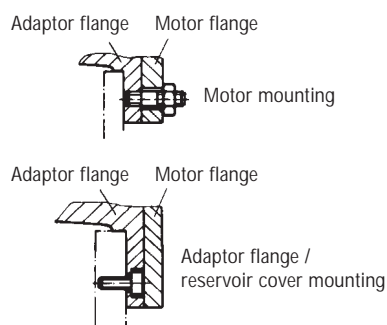

Ordering Example:

KF 3/100 F1 OB POA 7DP2 – Type ZM 3/350/204

Type	Frame size	n = 1450 min ⁻¹ kW														Total weight kg
			a	b	c	e	f	g	g ₂	h	o	q ₂	R	s	w ₁	
ZM 3/350/204 ZN 3/350/204	160 M	11	210	254	22	254	314	324	-	160	354	154	234	15	108	122
	160 L	15	254	254	22	298	314	324	-	160	398	154	234	15	108	147
	180 M	18.5	241	279	22	285	342	364	-	180	387	175	269	15	121	175
	180 L	22	279	279	22	323	342	364	-	180	425	175	269	15	121	188
ZM 4/350/204 ZN 4/350/204	160 M	11	210	254	22	254	314	324	-	160	354	154	234	15	108	130
	160 L	15	254	254	22	298	314	324	-	160	398	154	234	15	108	155
	180 M	18.5	241	279	22	285	342	364	-	180	387	175	269	15	121	182
	180 L	22	279	279	22	323	342	364	-	180	425	175	269	15	121	195
ZM 5/350/204 ZN 5/350/204	160 M	11	210	254	22	254	314	324	-	160	354	154	234	15	108	141
	160 L	15	254	254	22	298	314	324	-	160	398	154	234	15	108	166
	180 M	18.5	241	279	22	285	342	364	-	180	387	175	269	15	121	193
	180 L	22	279	279	22	323	342	364	-	180	425	175	269	15	121	206
ZM 6/350/237 ZN 6/350/237	160 M	11	210	254	22	254	314	324	-	160	354	154	234	15	108	168
	160 L	15	254	254	22	298	314	324	-	160	398	154	234	15	108	193
	180 M	18.5	241	279	22	285	342	364	-	180	387	175	269	15	121	221
	180 L	22	279	279	22	323	342	364	-	180	425	175	269	15	121	234
ZM 6/400/228 ZN 6/400/228	200 LK	30	305	318	28	385	392	404	-	200	508	183	306	19	133	318
ZM 6/450/262 ZN 6/450/262	225 S	37	286	356	32	370	441	485	190	225	372	301	352	19	149	408
	225 M	45	311	356	32	370	441	485	190	225	372	301	352	19	149	448
ZM 6/550/275 ZN 6/550/275	250 M	55	349	406	35	439	496	485	190	250	442.5	292.5	352	24	168	538

The values specified in the table above relate to ABB motors only. (Motors from other manufacturers are available on request)

Ordering example: KF 3/100 F1 OB POA 7DP2 – Type Z 3/350/204 with 3-phase motor 230/400 V; 50 Hz; IP 55; 1450 min⁻¹

When ordering a flange-type pump with electric motor please specify the rated voltage, the frequency, the speed and the enclose requested.

Gear Pumps KF

Accessories, 4-bolt, Flanged Pipe Connections

Welding connector KF 3, KF 4

Ordering Example:

2 Pieces Welding Connector KF 4

complete welding connector with gasket and screws for the size KF 4

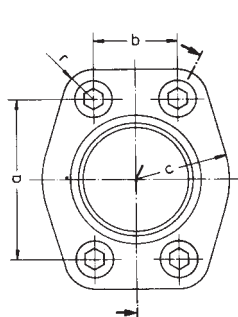

Material: ST 42-2

Welding connector KF 5, KF 6

Ordering Example:

2 Pieces Welding Connector KF 5

complete welding connector with gasket and screws for the size KF 5 / 250

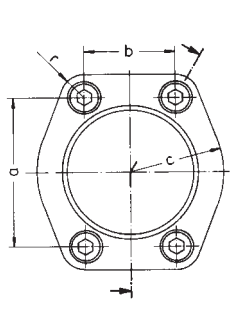

Material: ST 42-2

Size	Nom-displacement												Screws DIN 912-8.8	Nom-size	Pipe external Ø	Weight kg	
		a	b	c	e	f	g	h	m	n	r	s					t
KF3		69.9	35.7	40	9	M10	13	24	45	49	13	15	-	M10x25	40	448.3	0.44
KF4		77.8	42.9	50	9	M12	17	24	57	61	13	15	-	M12x30	50	60.3	0.63
KF5 / 200		88.9	50.8	55	-	M12	16	18	68	77	15	12	12	M12x35	65	76.1	0.86
KF5 / 250 / 315		106.4	61.9	65	-	M12	16	18	82	90	15	12	12	M12x35	80	88.9	1.2
KF6		130.2	77.8	80	-	M16	24	24	107	115.3	20	15	20	M16x50	100	114.3	2.5

Threaded connector KF 3, KF 4

Ordering Example:

2 Pieces Threaded Connector KF 4

complete threaded connector with gasket and screws for the size KF 4

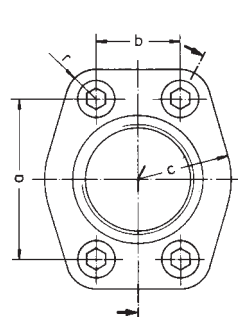

Material: ST 42-2

Size												Screws DIN 912-8.8	Weight kg
	a	b	c	d	e	f	g	h	r	t			
KF3	69.9	35.7	40	G 1½	9	M10	13	24	13	-	M10x25	0.44	
KF4	77.8	42.9	50	G2	9	M12	17	24	13	-	M12x30	0.63	

Accessories, Couplings

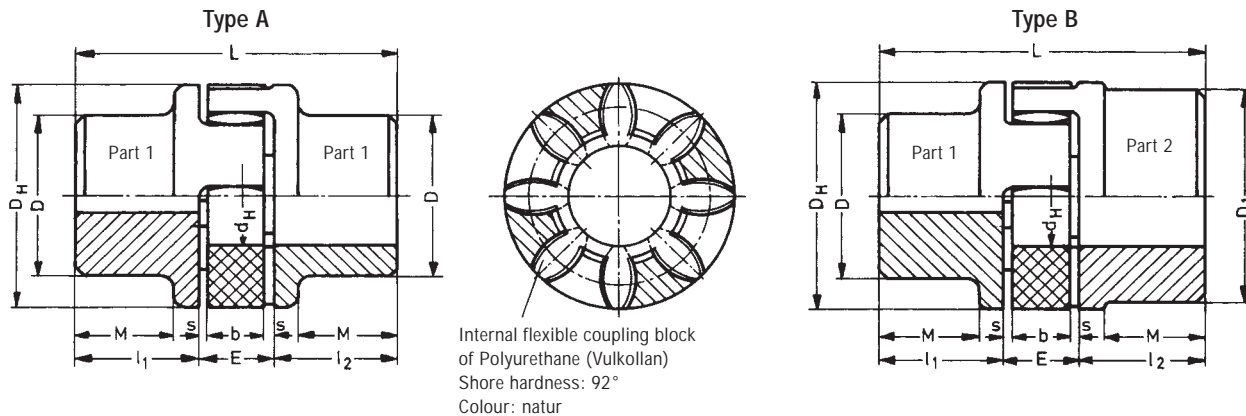

	Coupling-size	Hub material: Aluminium		Rough bore		Finished bore				Dimensions								Ordering code		
		Weight Kg	Moment of inertia Kgm ²	Part 1	Part 2	min. Part 1	min. Part 2	max. Part 1	max. Part 2	l ₁ ; l ₂	E	s	b	L	M	D _H	D		D ₁	d _h
Type A	28	0.39	0.0002	8	-	10	-	28	-	35	20	2.5	15	90	28	65	48	-	30	RA 28-Z 35/...-Z 35/..
	38	0.82	0.0007	10	-	12	-	38	-	45	24	3	18	114	37	80	66	-	38	RA 38-Z 45/...-Z 45/..
Type B	24/28	0.26	0.0001	6	22	8	24	24	28	30	18	2	14	78	24	55	40	48	27	RA 24/28-Z 30/...-Z 30/..
	28/38	0.46	0.0003	8	26	10	28	28	38	35	20	2.5	15	90	28	65	48	65	30	RA 28/28-Z 35/...-Z 35/..
	38/45	0.89	0.0008	10	36	12	38	38	45	45	24	3	18	114	37	80	66	76	38	RA 38/45-Z 45/...-Z 45/..
	38/45	0.89	0.002	10	36	12	38	38	45	45/70	24	3	18	139	37	80	66	76	38	RA 38/45-Z 45/...-Z 70/..
	42/55	1.39	0.0018	12	40	14	42	42	55	50	26	3	20	126	40	95	75	94	46	RA 42/55-Z 35/...-Z 50/..
	42/55	1.39	0.005	12	40	14	42	42	55	50/75	26	3	20	151	40	95	75	94	46	RA 42/55-Z 35/...-Z 75/..
	48/60	1.86	0.003	13	46	15	48	48	60	56	28	3.5	21	140	45	105	85	102	51	RA 48/60-Z 35/...-Z 56/..
55/70	7.37	0.016	18	52	20	55	55	70	65	30	4	22	160	-	120	98	120	60	RA 55/70-Z 65/...-Z 65/..	

Operating temperature: -10 °C to +80 °C (short-time temperature peaks up to +120 °C are permissible)
Weights as well as moments of inertia relate to the max. bore dia. after final machining – but without key way.
Bore finish acc. to ISO – fit, class H7;
Key-ways acc. to DIN 6885 / part 1

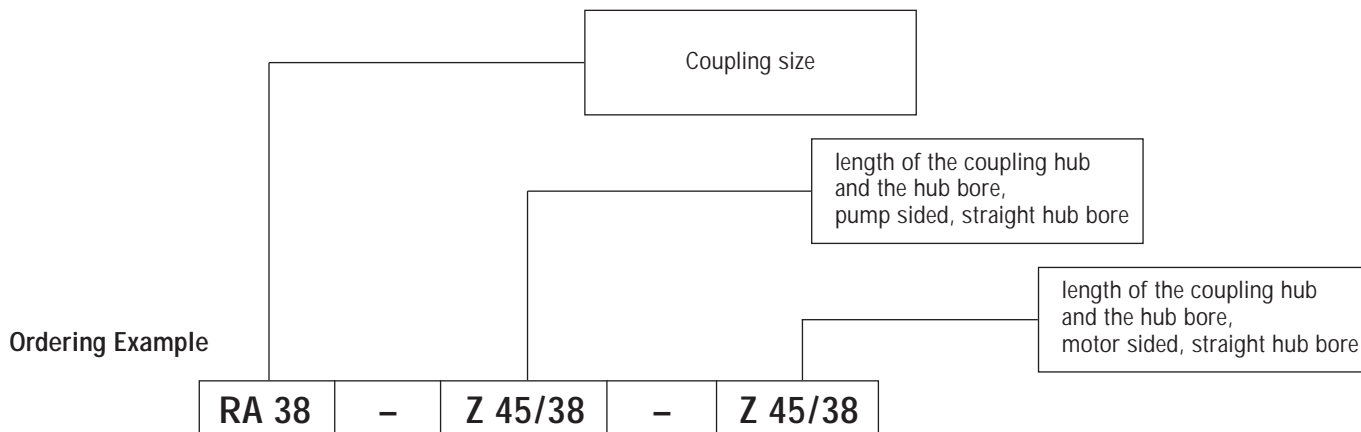

Gear Pumps KF

Flange-Type Pumps with Mounting Angle

Materials

Housing components: Cast iron with lamellar graphite acc. to DIN 1691

Shafts and gears: Case hardening steel acc. to DIN 17210 surface hardened and grinded

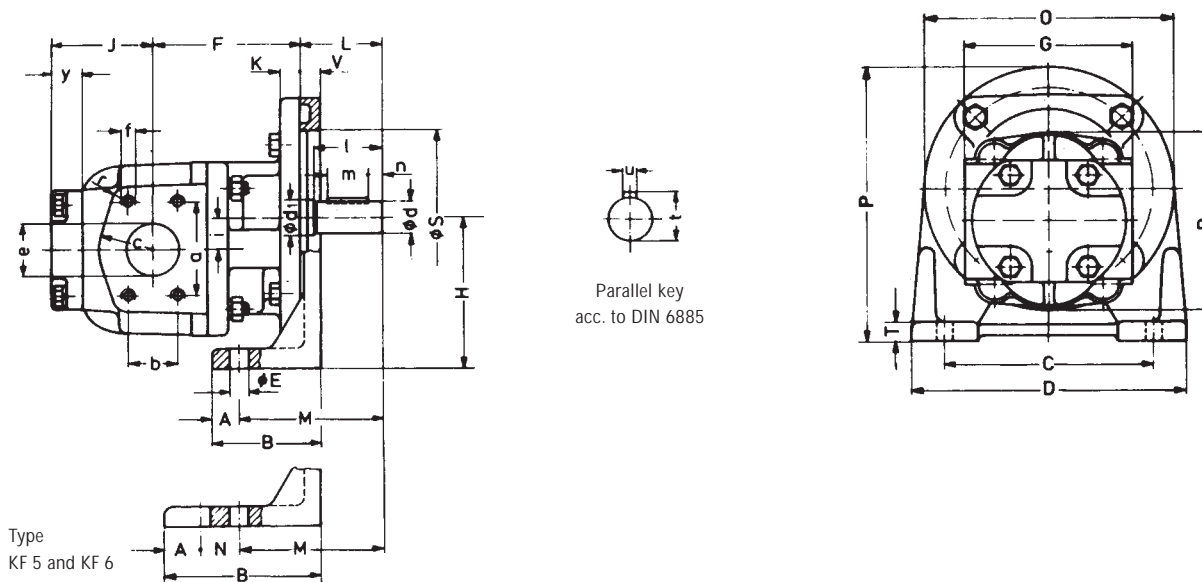

Mounting angle dimensions

	A	B	C	D	E	H	M	N	O	P	T	V
KF 3	20	80	150	180	14	112	105	-	180	202	15	15
KF 4	20	95	170	200	14	132	115	-	220	242	15	20
KF 5	40	220	180	220	14	160	190	40	250	285	18	20
KF 6	45	285	250	300	18	200	240	70	250	325	22	25

Size	Inlet- and outlet port flange							Shaft end										Weight kg						
	a	b	c	e	f	r	F	G	J	K	L	R	S _{h7} S _{h6}	i	Y	d ₁	d _{k6}		l	m	n	t	u	
3/ 100 112	69.9	35.7	40	40	M10	16 deep	12	108	120	92	15	60	130	130	23	20	25	24	50	30	10	27	8	
																	20	19			5	21.5	6	14
4/ 150 180	77.8	42.9	50	50	M12	18 deep	12	110	130	77	19	60	160	150	28.3	20	25	24	50	40	5	27	8	
								125									135	77			23	23		
5/ 200 250 315	88.9	50.8	50	63	M12	20 deep	13	155	170	150	109	22	70	198	180	32	24	30	28	60	40	10	31	8
							15											170	109			24	36.5	
							15											170	109			24	36.5	
6/ 400 500 630	130.2	77.8	80	100	M16	32 tief	20	180	200	200	126	25	95	244	180	40	24	40	38	80	63	8	41	10
							20											200	159			10	63	
							20											200	159			10	73	

Gear Pumps KF

Characteristic Curves

Charts for KF 3/100 ... KF 3/112

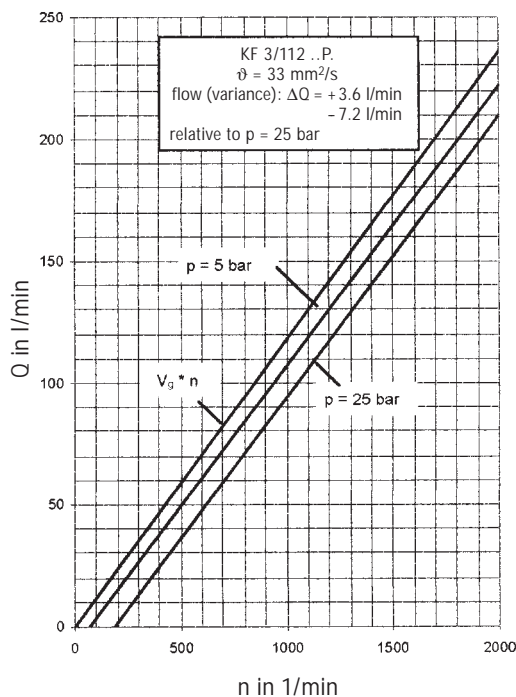
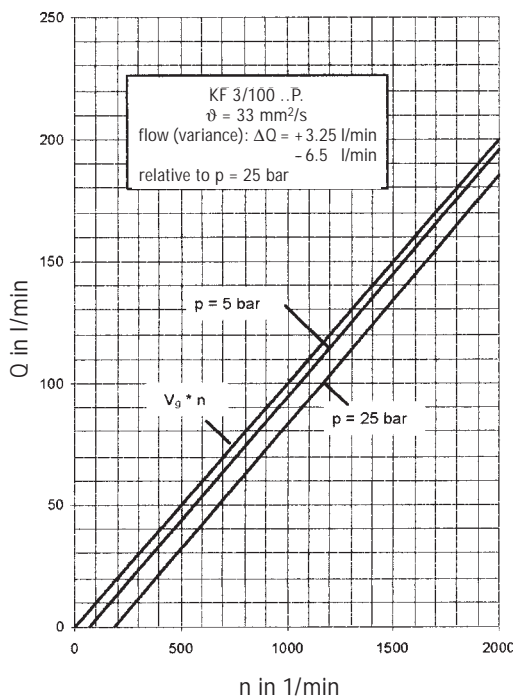

Charts for KF 4/125 ... KF 4/180

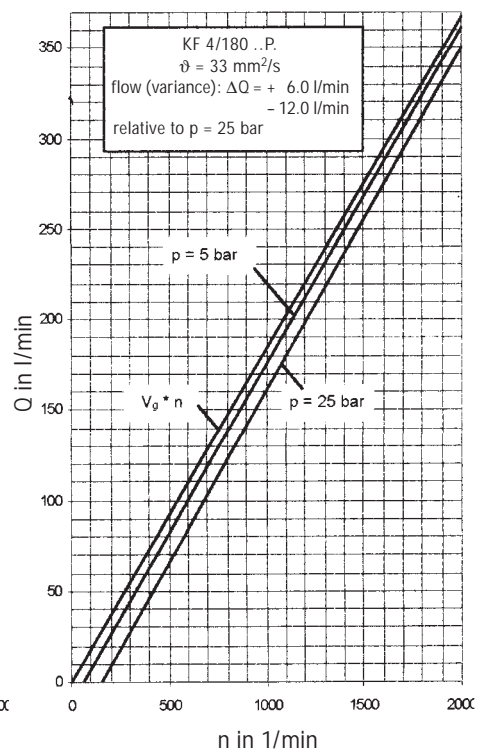
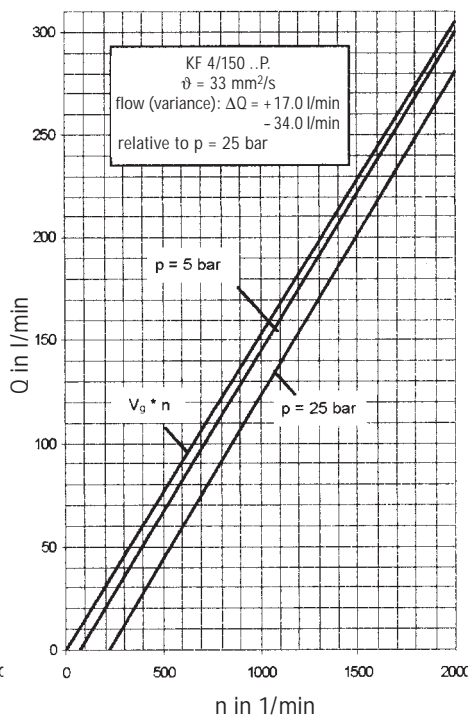
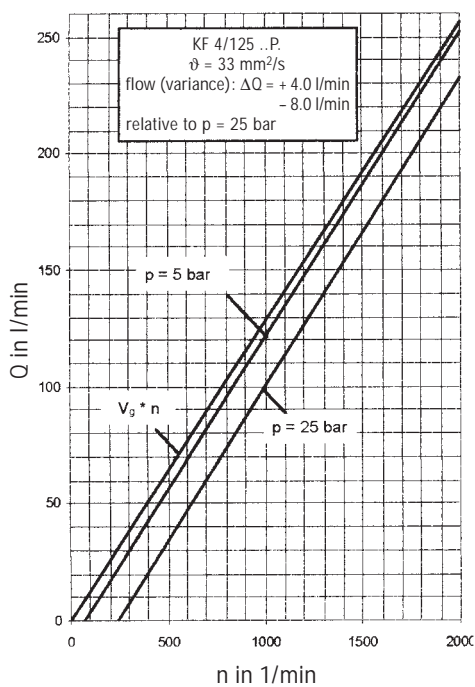

Gear Pumps KF

Characteristic Curves

Charts for KF 5/200 ... KF 5/315

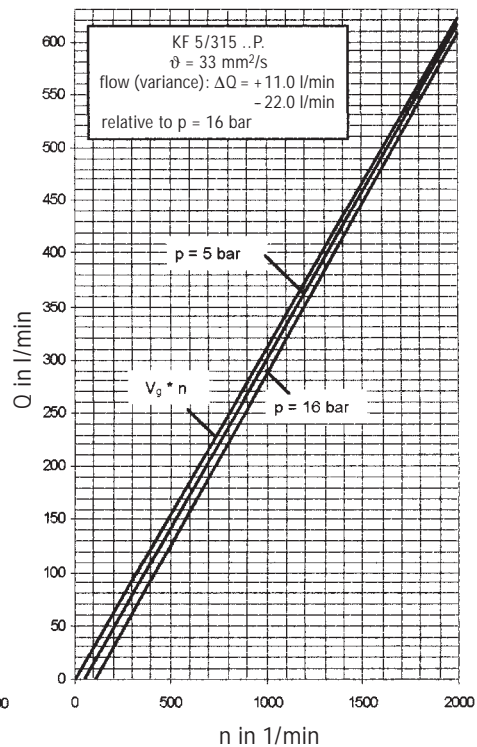
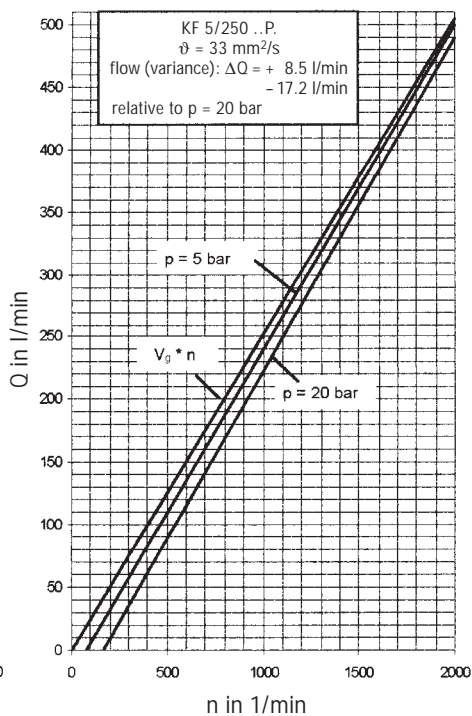
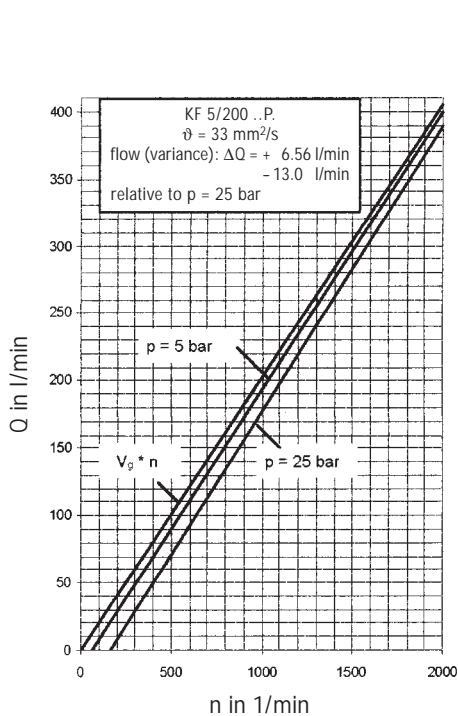

Charts for KF 6/400 ... KF 6/630

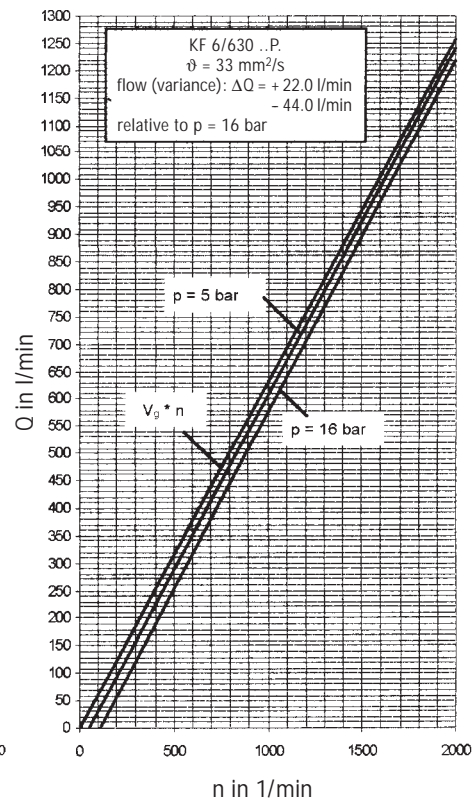
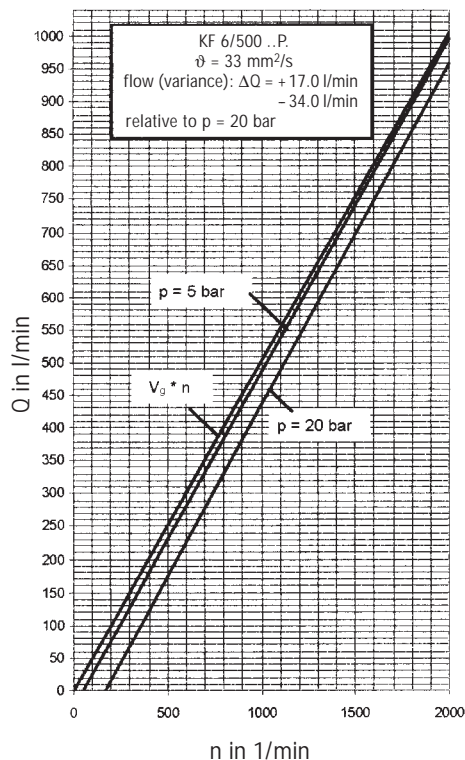
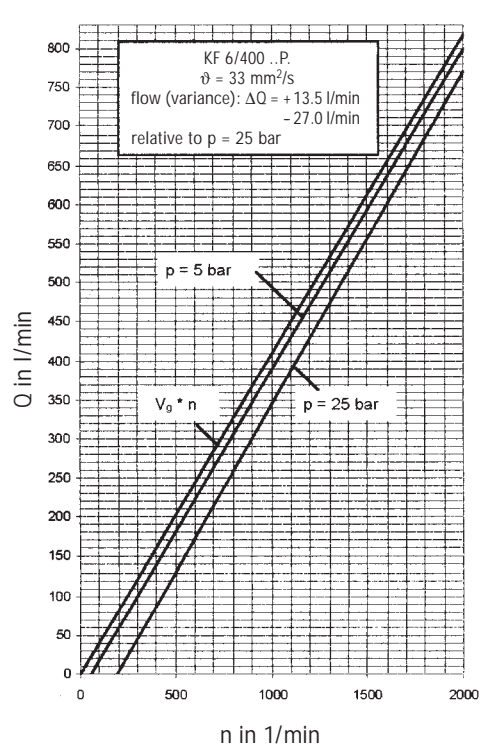

Overview of our complete program

Transfer pumps

Transfer pumps for lubricating oil supply equipment, low pressure filling and feed systems, dosing and mixing systems.

Volutronic®

Gear flow meters and electronics for volume and flow metering technology in hydraulics, processing and laquering technology.

Mobile hydraulics

Single and multistage high pressure gear pumps, hydraulic motors and valves for construction machinery, lorry-mounted machines.

Industrial hydraulics

Cetop directional control and proportional valves, hydraulic cylinders, pressure, quantity and stop valves for pipe and slab construction, hydraulic accessories for industrial hydraulics (mobile and stationary use).

With our decades of experience, we are at your side, world-wide, for the professional mastery of specific applications and complete solutions in hydraulics and process technology.



KF3-6.e.10.99